



PARTS PRICE LIST : QP-402S

No.	PARTS NO.	PARTS NAME	QTY	MATERIAL
	GX240	ENGINE		
1	9430-100010	CASING	1	ADC
2	9430-100020	CASING COVER	1	ADC
3	9430-100160	SUCTION COVER	1	ADC
4	1445-000130	VOLUTE CASING	1	FC
5	4418-000030	IMPELLER	1	FC
6	079000-4040-0011	NIPPLE	1	FC
7	079890-4040-0011	SOCKET	1	FC
8	1434-214010-0014	FRAME	1	SS400
9	1440-214020-0014	ENGINE BASE	1	SS400
10	1445-081220	LINER RING	1	BC
11	048935-3850	O-RING (CASING)	1	NBR
12	048935-2400	O-RING (SUCTION COVER)	1	NBR
13	048131-0950	O-RING (VOLUTE CASING)	1	NBR
14	048131-1000	O-RING (SOCKET)	1	NBR
15	048131-1100	O-RING (NIPPLE)	1	NBR
16	048220-0240	O-RING (MECH SEAL SLEEVE)	1	NBR
17	048035-0300	O-RING(FLOODING/DRAIN CAP)	2	NBR
18	085283-4525	ADJUST LINER	1	BSP
18-1	085285-4525	ADJUST LINER	1	BSP

No.	PARTS NO.	PARTS NAME	QTY	MATERIAL
19	9430-350350	CHECK VALVE	1	NBR+SS400
20	072330-2040	CUSHION RUBBER	4	NBR+SS400
21	080611-3630	MECHANICAL SEAL	1	CERAMIC× CARBON
22	081188-3051	MECHANICAL SEAL SLEEVE	1	SUS
23	063121-1100ASSY	FLOODING/DRAIN CAP WITH O-RING	2	ABS
24	010505-0820	BOLT	4	SS400
25	010505-1240	BOLT	4	SS400
26	010505-1250	BOLT	1	SS400
27	010505-1040	BOLT	6	SS400
28	010505-1045	BOLT	4	SS400
29	019116-0625	BOLT	4	SS400
30	020545-0100	NUT	14	SS400
31	045125-0120	SPRING WASHER	5	SWRH
32	045125-0100	SPRING WASHER	24	SWRH
33	040145-0100	WASHER	4	SS400
34	014109-0616	SCREW	2	SUS
35	040145-0060	WASHER	2	SS400
36	074111-1100	HOSE COUPLING	2	ADC
37	074124-1100	HOSE JOINT	2	ADC
38	074132-1001	HOSE COUPLING PACKING	2	NBR

 MATSUSAKA ENGINEERING CO., LTD.

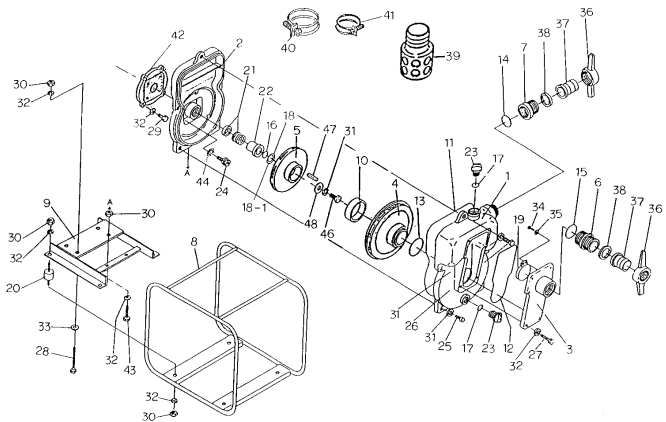
No.	PARTS NO.	PARTS NAME	QTY	MATERIAL
39	074221-2100	STRAINER	1	SS400
40	093225-4000	WIRE HOSE BAND	2	SWRM
41	093225-0110	WIRE HOSE BAND	1	SWRM
42	4313-000600-0011	CASING COVER SET PLATE	1	FC
43	010505-1040	BOLT	2	SS400
44	045822-0080	SEAL WASHER	4	SUS+NBR
46	019115-0730	IMPELLER SET BOLT	1	SS400
47	052004-0422	KEY	1	S45C
48	4334-201240-0011	IMPELLER WASHER	1	FC

 MATSUSAKA ENGINEERING CO., LTD.