

GX 620

Horizontal shaft gasoline (petrol) engine



Moteur à essence à arbre de prise de force horizontal

Benzinmotor mit horizontaler Kurbelwelle

Motore a benzina ad albero orizzontale

Bensinmotor med horisontell axel

Benzinmotor met horizontale uitgaande as

GX 620

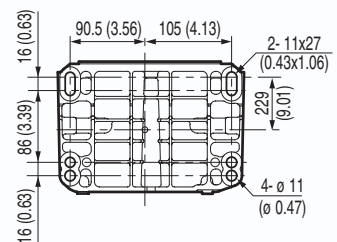
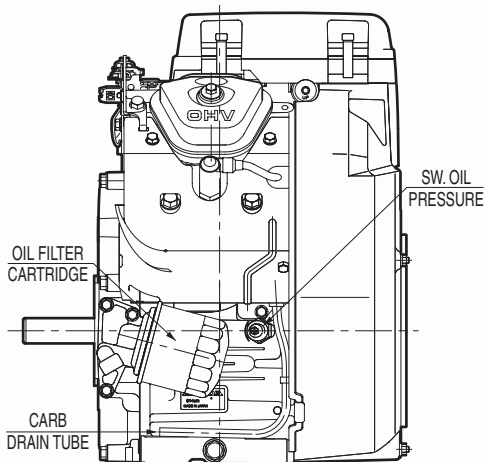
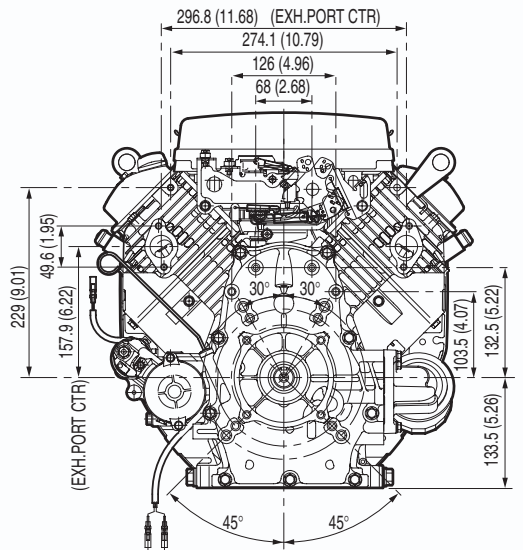
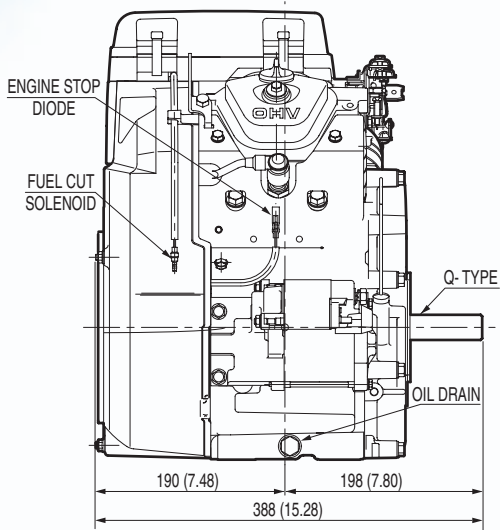
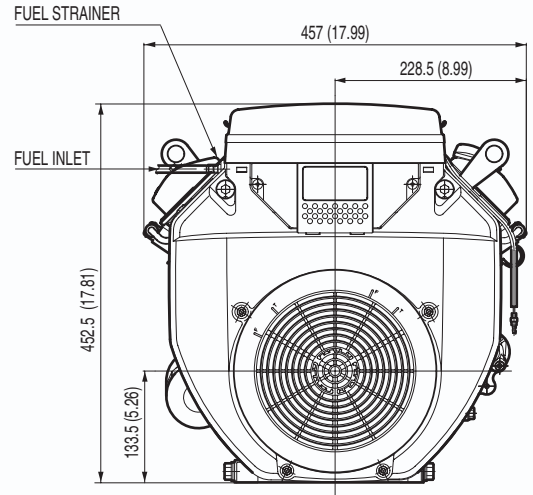
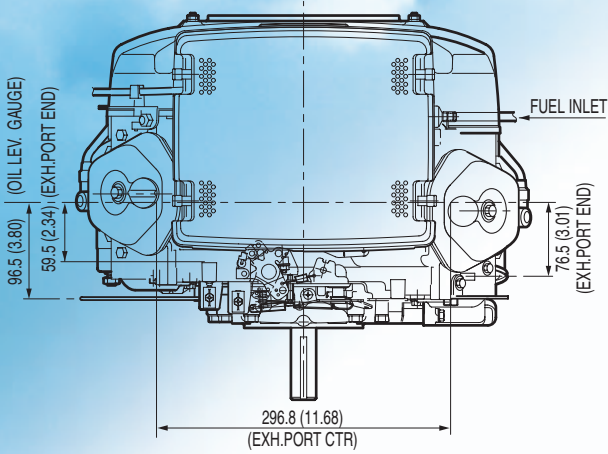

Dimensions Unit: mm (in.)

STANDARD TYPE

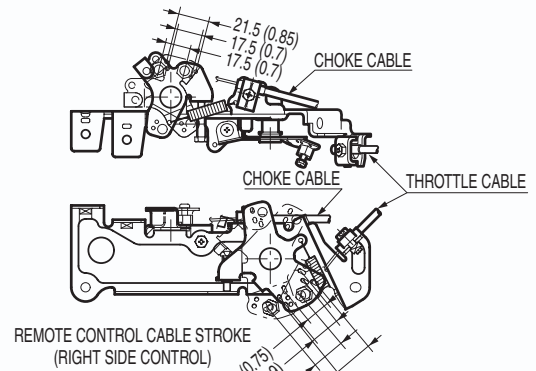
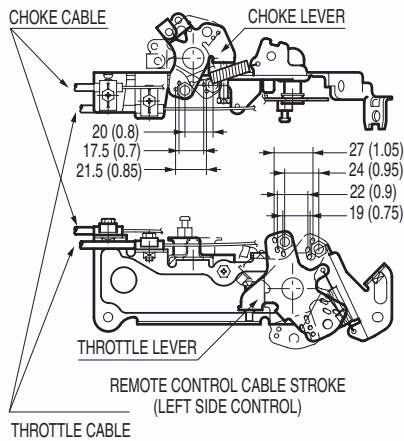

PTO SHAFT DIMENSIONS

Q-TYPE

V-TYPE

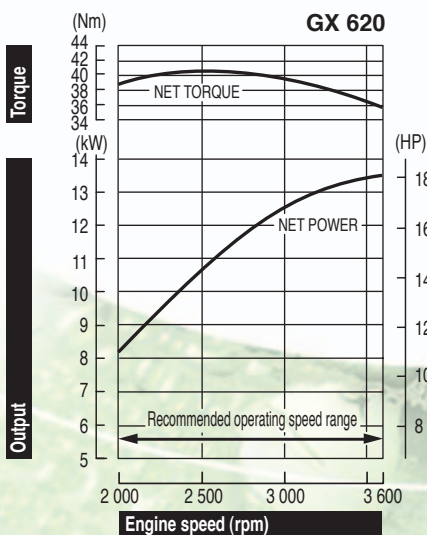
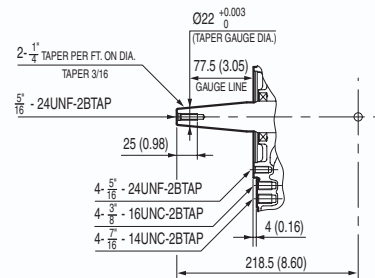
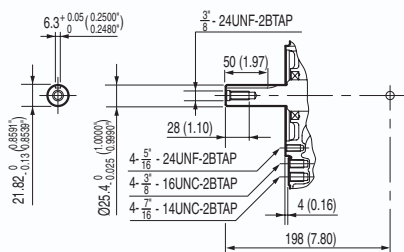

The power rating of the engine indicated in this document is the net power tested on a production engine for the engine model and measured in accordance with SAE J1349 at a specified rpm. Mass production engines may vary from this value. Actual power output for the engine installed in the final machine will vary depending on numerous factors, including the operating speed of the engine in application, environmental conditions, maintenance, and other variables.

La puissance du moteur indiquée dans ce document est une puissance nette obtenue par l'essai d'un moteur de série selon la norme SAE J 1349 à une vitesse de rotation donnée. La puissance d'un autre moteur de production peut être différente de cette valeur indiquée. La puissance réelle d'un moteur installé sur une machine dépendra de différents facteurs comme la vitesse de rotation, les conditions de température, d'humidité, de pression atmosphérique, de maintenance et autres.

Die Leistungsangabe der in diesem Dokument aufgeführten Motoren ist die Netto-Leistung gemäß SAE J1349, getestet bei einer definierten Drehzahl an einem Produktionsmotor. Bei Motoren aus Serienproduktion kann der Wert abweichen. Die Leistungsabgabe in einem Fertigerät weicht, bedingt durch unterschiedliche Faktoren, wie Motordrehzahl in der Applikation, Umwelteinflüsse, Grad der Instandhaltung und andere Einflüsse ab.

La potenza indicata in questo documento, è la potenza netta rilevata su questo modello di motore in fase di produzione, ed è stata misurata secondo la procedura SAE J1349 ad un numero di giri specifico. Nella produzione di massa si possono riscontrare variazioni rispetto a questi valori. La potenza del motore installato nella macchina può dipendere da numerosi fattori, incluso il numero di giri al quale il motore è impiegato, le condizioni ambientali, dal livello di manutenzione ed altre variabili.

De bepaling van het vermogen van de motor, vermeld in dit document, is het netto vermogen getest op een productiemotor en gemeten in overeenstemming met SAE J1349 aan een specifieke t/min. Motoren van massaproductie kunnen van deze waarde variëren. Het werkelijke vermogen van de geïnstalleerde motor in het eindproduct kan afwijken, afhankelijk van talrijke factoren, zoals de operationele snelheid van de motor in een applicatie, omgevingsfactoren, onderhoud en andere variabelen.

Den i detta dokument nämnda motors effekt, är uppmätt i netto effekt. I enlighet med mätmetoden SAE J1349. Massproducerade motorer kan avvika från nämnda värde. Den faktiska effekten för varje motor kan variera beroende på bl a. varvtal, yttre omgivningar, underhåll, typ av applikation, mm.

Specifications

Model GX 620	
Engine type	Air cooled 4-stroke OHV petrol engine, 90° V-twin design, horizontal shaft
Bore x stroke	77 x 66 mm
Displacement	614 cm ³
Compression ratio	8.3 : 1
Net power	13.5 kW (18.1 HP) / 3 600 rpm
Cont. rated power	10.3 kW (13.8 HP) / 3 000 rpm 11.8 kW (15.8 HP) / 3 600 rpm
Max. net torque	40.6 Nm / 4.14 kgfm / 2 500 rpm
Ignition system	Transistorised
Starting system	Electric starter
Fuel cons. at rated power	5.7 L/hr - 3 600 rpm
Engine oil capacity	1.8 l
Dimensions (L x W x H)	388 x 457 x 452 mm
Dry weight	42 kg

Spezifikationen

Modell GX 620	
Motortyp	Luftgekühlter 2-Zylinder 4-Takt OHV Benzinmotor, 90° V-Twin, horizontale Kurbelwelle
Bohrung x Hub	77 x 66 mm
Hubraum	614 cm ³
Verdichtung	8.3 : 1
Netto-Leistung	13.5 kW (18.1 HP) / 3 600 min ⁻¹
Max. Dauerleistung	10.3 kW (13.8 HP) / 3 000 min ⁻¹ 11.8 kW (15.8 HP) / 3 600 min ⁻¹
Max. Netto-Drehmoment	40.6 Nm / 4.14 kgfm / 2 500 min ⁻¹
Zündsystem	Elektronische Zündung
Starter	Elektrostarter
Benzinverbrauch bei Dauerleistung	5.7 L/h - 3 600 min ⁻¹
Motorölkapazität	1.8 Liter
Maße (L x B x H)	388 x 457 x 452 mm
Trockengewicht	42 kg

Specificaties

Model GX 620	
Motortype	luchtgekoelde 4-takt OHV benzine-motor, 90° v-twin, horizontale uitgaande as
Boring x slag	77 x 66 mm
Cilinderinhoud	614 cm ³
Compressie	8.3 : 1
Netto vermogen	13.5 kW (18.1 HP) / 3 600 t/min
Continu nominaal vermogen	10.3 kW (13.8 HP) / 3 000 t/min 11.8 kW (15.8 HP) / 3 600 t/min
Max. netto koppel	40.6 Nm / 4.14 kgfm / 2 500 t/min
Ontsteking	Electronische ontsteking
Startsysteem	Electrische start
Brandstofverbruik aan nominaal vermogen	5.7 l/u - 3 600 t/min
Motoroliecapaciteit	1.8 Liter
Afmetingen (L x B x H)	388 x 457 x 452 mm
Drooggewicht	42 kg

Spécifications techniques

Modèle GX 620	
Type du moteur	Moteur à essence bicylindre 4 temps OHV, refroidissement à air, cyl. en V à 90°, arbre de prise de force horizontal, cyl. chemisé en fonte
Alésage x course	77 x 66 mm
Cylindrée	614 cm ³
Taux de compression	8.3 : 1
Puissance nette	13.5 kW (18.1 HP) / 3 600 tr/mn
Puissance en service continu	10.3 kW (13.8 HP) / 3 000 tr/mn 11.8 kW (15.8 HP) / 3 600 tr/mn
Couple maximum	40.6 Nm / 4.14 kgfm / 2 500 tr/mn
Système d'allumage	Transistorisé
Système de démarrage	Démarrateur électrique
Consommation de carburant en service continu	5.7 litre(s)/heure - 3 600 tr/mn
Capacité d'huile moteur	1.8 l
Dimensions (L x l x H)	388 x 457 x 452 mm
Poids à sec	42 kg

Dati tecnici

Tipo GX 620	
Tipo di motore	Motore bicilindrico OHV ad albero orizzontale ciclo otto, 4 tempi, cilindri disposti a V di 90° raffreddamento ad aria forzata
Alesaggio x corsa	77 x 66 mm
Cilindrata	614 cm ³
Rapporto di compressione	8.3 : 1
Potenza netta	13.5 kW (18.1 HP) / 3 600 giri/min
Potenza nominale continua	10.3 kW (13.8 HP) / 3 000 giri/min 11.8 kW (15.8 HP) / 3 600 giri/min
Coppia massima	40.6 Nm / 4.14 kgfm / 2 500 giri/min
Accensione	A transistor senza contatti
Avviamento	Elettrico
Consumo combustibile alla potenza nominale	5.7 Litri/ora - 3 600 giri/min
Capacità coppa olio	1.8 Litri
Dimensioni (Lu x La x A)	388 x 457 x 452 mm
Peso a secco	42 kg

Spécifikationer

Modell GX 620	
Motortyp	Luftkyld 4-takts bensinmotor med överliggande ventiler, 90° V-twin design, Horisontal axel
Cylinderdiameter x slaglängd	77 x 66 mm
Slagvolym	614 cm ³
Kompressionsförhållande	8.3 : 1
Netto effekt	13.5 kW (18.1 HP) / 3 600 varv per minut
Rek. kontinuerlig effekt	10.3 kW (13.8 HP) / 3 000 varv per minut 11.8 kW (15.8 HP) / 3 600 varv per minut
Max. netto vridmoment	40.6 Nm / 4.14 kgfm / 2 500 varv per minut
Tändsystem	Transistor
Startsystem	Elektrisk start
Bränsleförbrukning vid märkeffekt	5.7 L/tim - 3 600 varv per minut
Oljevolym	1.8 Liter
Dimensioner (L x B x H)	388 x 457 x 452 mm
Torrvikt	42 kg

HONDA
ENGINES

Honda Europe NV
EUROPEAN ENGINE CENTER
Langerbruggestraat 104
B-9000 Gent
TEL: + 32 (0)9 250 12 11
FAX: + 32 (0)9 250 14 24

www.honda-engines-eu.com

France • European Engine Center • Product information center

Parc d'Activités de Pariest • Allée du 1er Mai, BP 46 • Croissy Beaubourg • F-77312 Marne-la-Vallée Cedex 2
TEL: + 33 (0)1 60 37 31 18 • FAX: + 33 (0)1 60 37 33 66

Germany • Honda Engines • Selling agent

Honda Logistik Center Deutschland GmbH • Sprendlinger Landstraße 166 • D-63069 Offenbach/Main
TEL: + 49 (0)6 98 30 93 65 • FAX: + 49 (0)6 98 30 91 28

Italy • Honda Engines • Selling agent

Honda Logistic Centre Italy S.p.A. • Via Strà 153 - 154 • I-37030 Colognola ai Colli (VR)
TEL: + 39 045 6173341 • FAX: + 39 045 6151270

Sweden • Honda Engines • Selling agent

Honda Logistics Center Sweden AB • Box 50583 • Väst kustvägen 17 • SE-20215 Malmö
TEL: + 46 40 38 07 00 • FAX: + 46 40 38 07 88

United Kingdom • Honda Engines • Selling agent

Honda Logistics Centre (UK) Ltd. • Viscount Way, South Marston Park • Swindon SN3 4TN, UK
TEL: + 44 (0)1 455 55 94 29 • FAX: + 44 (0)1 455 55 94 28

All specifications are subject to change without notice.
Les caractéristiques techniques peuvent être modifiées à tout moment et sans préavis.
Spécifikationer kan ändras utan föregående meddelande.

Le specifiche sono soggette a cambiamento senza preavviso.
Die Spezifikationen können ohne Vorankündigung geändert werden.
Alle technische specificaties kunnen op elk ogenblik en zonder kennisgeving gewijzigd worden.

Ref. EEC - TS 2007/4 - GX 620

© www.honda.com